

Product Image



Die Cast Liquid Tite Connectors – Straight Insulated

Insulated die cast liquid tight connectors are used to connect metallic and non-metallic liquid tight conduit to a weatherproof outlet box and various other electrical enclosures.

Features:

- UL listed and CSA certified
- Zinc die cast
- 105°C rated throat insulators
- Available insulated & non-insulated

Dimensional Data

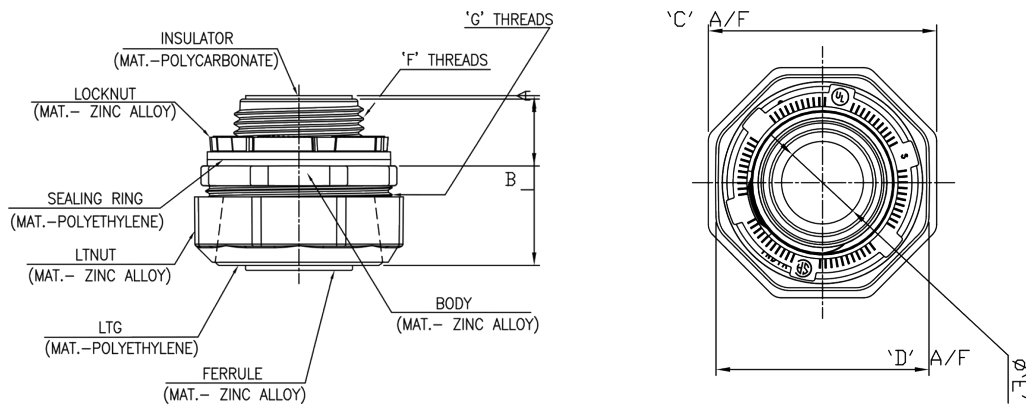

PN#	Size	"A" with Insulator	"B"	"C"	"D"	"ØE"	"F" NPT Thread	"G" UNEF Thread
LT38I	3/8"	39.33	13.34	32.55	30.50	10.60	1/2"	1-3/16"
LT50I	1/2"	38.32	13.39	33.22	31.01	13.37	1/2"	1-3/16"
LT75I	3/4"	39.93	13.00	40.00	37.60	18.18	3/4"	1-7/16"
LT100I	1"	49.00	17.25	46.06	44.40	24.00	1"	1-11/16"
LT125I	1-1/4"	52.26	16.69	57.38	56.55	32.40	1-1/4"	2-1/8"
LT150I	1-1/2"	51.60	16.60	63.61	63.17	37.23	1-1/2"	2-3/8"
LT200I	2"	51.69	16.70	76.14	75.58	48.28	2"	2-7/8"
LT250I	2-1/2"	85.26	24.66	93.50	91.60	57.80	2-1/2"	3-1/2" UNS
LT300I	3"	88.27	24.56	109.23	107.20	73.86	3"	4" UNS
LT350I	3-1/2"	103.05	27.00	122.48	120.41	84.33	3-1/2"	4-1/2" UNS
LT400I	4"	102.95	27.12	131.48	130.19	96.80	4"	5" UNS

The liquid tight connectors were wet location tested and oil spray tested per UL514b per clause 8.7 and 8.17.6 . Both tests simulates rain and falling liquids. Therefore, the liquid tight connectors are liquid tight, but are not submersible.